

# Automated Parking System for Nonholonomic Cars

Utkarsh Sharma<sup>1</sup>, Gaurav Gupta<sup>2</sup>, Pardeep Garg<sup>3</sup>, Akash Garg<sup>4</sup>

B.Tech (Student), Department of Electronics and Communications Engineering,

Jaypee University of Information Technology, Wagnaghat, Solan, Himachal Pradesh, India<sup>1, 2, 4</sup>

Faculty of Engineering, Department of Electronics and Communications Engineering,

Jaypee University of Information Technology, Wagnaghat, Solan, Himachal Pradesh, India<sup>3</sup>

**Abstract:** This paper presents an idea of automating a car parking system in order to save and reduce the time, skills and energy required for parking cars conventionally. As nowadays there is shortage of space, this system model will also help in building parking spaces which are more compact and secure because of human less entry of cars in parking system. Our system model works in two modules, one of which is a model of a smart car and second is the smart parking area that is designed in such a way that the smart car suitably works on it. The car is basically guided by the smart parking area to park it correctly. The smart parking area stores the owner's information like his phone number and his corresponding car information in the form of car registration number. After getting these details the parking area controller automatically allocates an empty parking slot to the car and the smart car gets automatically parked to that allocated slot. Also a message (with OTP, for security purpose) regarding successful car parking is sent to car owner. Using this OTP car owner can take his car back after paying parking fee.

**Keywords:** Automated Parking System (APS), AVR Microcontroller, Infrared Sensor, GSM Module.

## I. INTRODUCTION

Due to increase in malls and multiplex culture there has been a significant increase in car parking problems. Sometimes there are many lanes for car parking and one has to look for all the lanes in order to park the car while sometimes there is no space for parking due to shortage of parking spaces. Conventionally there is no monitoring system for parking also. All the vehicles enter into the parking space and search for space wasting their time as well as fuel moreover results in blockage and havoc. Conditions become worse when there are multiple parking lanes and each of the lanes has multiple parking slots.

Moreover there is a lot of labour involved for this process which also requires lots of investment. So there is a need to develop a system where person leaves his car in parking entry and the car automatically gets parked. Use of automated system for car parking monitoring will reduce the human effort which is the main motive of automation. Automated parking system counts on many benefits. Havoc and waiting time during parking is significantly reduced. It is definitely a boon for old-age as well as novice drivers who normally experience biggest difficulty while parking cars. Driving around in search of a parking space is removed, leading to reduction in harmful engine emissions. Biggest advantage comes as a common concept to decrease the area of parking spaces by removing the driver and passengers from the car before it is parked. This is effectively achieved when ceiling height is minimized.

Walkways, stairways or elevators are needed to accommodate pedestrians in the parking area. Enhanced security since there is no public access to parked cars. Moreover only minimal lighting system is needed and it also eliminates the need for parking attendants.



Figure 1. Automatic Parking



Figure 2. Manual Parking

Figure 1 depicts that automatic parking is compact whereas manual parking is full of glitches which many a times consumes lot of space.

## II. LITERATURE WORK

Lot of research has been done in the field of automated car parking system to provide best alternatives for easy, safe and quick car parking. One such idea was to read the registration number of the car from car number plate using image processing technique [1] and then using this car registration number finding out car entry time, car exit time and also time period for which car was parked which will help in collecting parking fee.

A automated car parking system was designed using sensors which works in three phases [2]. First phase was scanning phase in which the parking area is examined by the ultrasonic sensors mounted on the robot-car and a path is produced if the space is sufficient. Second phase was positioning phase in which the robot reverses to the edge of the parking space avoiding any collision. Finally in third phase i.e. manoeuvring phase, the robot moves to the parking position in the parking space in a unified pattern. One similar idea was presented which uses three ultrasonic sensors mounted at the front left corner of the car to obtain

the information of surrounding area of parking lot and a compass sensor mounted at the centre of the car to measure the posture of the car [3]. These four sensors help in deciding the turning angle of the car.

Another idea proposed was a design of an automated car parking system controlled by an android application [4] that controls the number of cars to be parked/un-parked within a parking area with the help of an Android Application.

Some smart parking systems were also embedded with technologies like GSM modules [5-6] for SMS services to provide more secure and user friendly parking system.

Few other researches were also done using nonholonomic vehicles [7] and soft-computing techniques [8].

Thus, our aim is to propose an automatic parking system in context of parking which are dependent on car drivers which will not only save time, money and energy but also overcome the limitations of such similar pre-existing systems.

### III. DESIGN METHODOLOGY

This idea basically consists of two modules. First module is to design a smart parking area and second module is to make a smart car. The basic idea is that when the car will arrive at the entry gate of the parking area the driver of that car will come out of the car and then he will enter his car's registration number and mobile phone number at the entry gate. As he enters the car registration number, the microcontroller of the smart parking area will automatically allocate a slot number corresponding to that car number according to the availability of empty slot. This allotted slot number will be displayed on LCD screen present on entry gate of parking area. If no slot is available, then a message showing 'Parking area full' will be displayed over the LCD screen. Now the driver will enter this slot number into his smart car using a keypad embedded on his car and after that the driver may leave for his work. The car will automatically enter the parking area and will get parked to its allocated slot. There will be an LDR sensor at every parking slot which will send a command to parking area controller regarding successful parking of car on its slot. When the car will be successfully parked at the allocated slot, a message from the parking area controller will be sent to the mobile phone of the car driver regarding successful parking of his car. Also a random number will be sent in this message which will serve as OTP (one time password) for better security purpose. For the movement of the car inside parking area we will use a setup of four infrared sensors on front bonnet of car. These IR sensors will help the car to move in straight path, and also to take left or right turn inside the parking area avoiding any collision. Also as the car enters the parking area, a timer will automatically start. When the car owner comes back, he has to enter his car details (like car registration number) on the keypad embedded at exit gate of parking area. Then for security checking, he will be asked to enter the OTP sent to him by message when his car was successfully parked. Using these details the microcontroller at parking area will guide that particular car to come out of its slot to the exit gate. As the car arrives to the exit gate the timer will stop and

using the time period for which car is parked parking fee will be calculated and displayed on LCD screen. The car owner has to pay that parking fee and then he can take his car back.

## IV. ARCHITECTURE DESIGN AND ALGORITHM

### A. SMART PARKING AREA

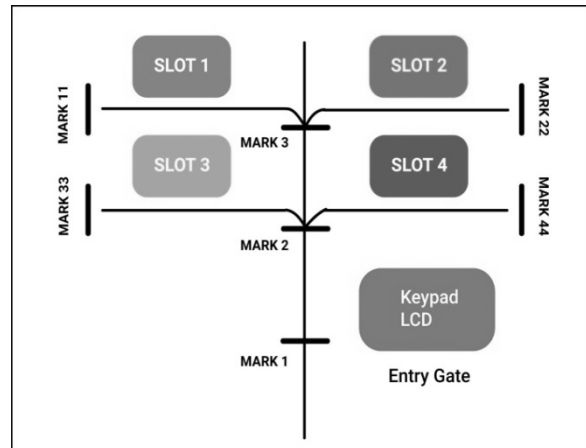
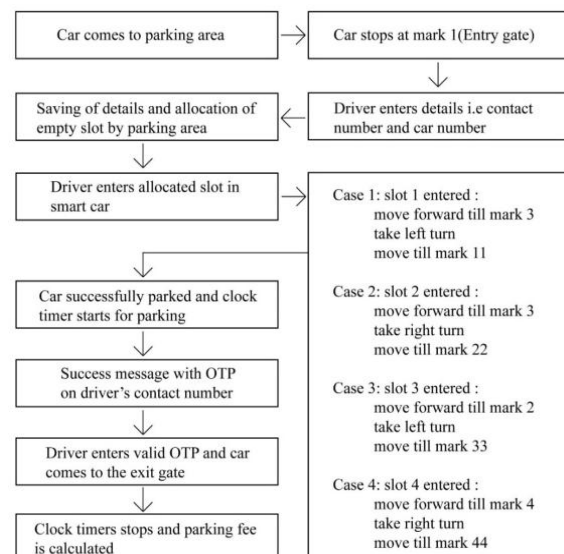

**Figure 3.** Layout of 'smart parking area'

Figure 3 illustrates smart parking area for four cars. The car will stop at entry gate which is marked with mark 1. The driver will enter his car registration number and his mobile phone number into the keypad embedded at the entry gate. In return an empty slot will be allocated to the car and that slot number will be displayed on LCD screen on entry gate itself.

If no slot is available then a sorry message will be displayed. Once a slot is allocated the car driver has to enter that slot number in an keypad embedded on smart car. The smart car will then automatically move inside the parking area and will get parked into its corresponding slot. Mark 2 and Mark 3 will be used to guide car towards its slot while Mark 11/22/33/44 are to indicate that the car has been parked successfully to that particular slot.

### Flow Control:

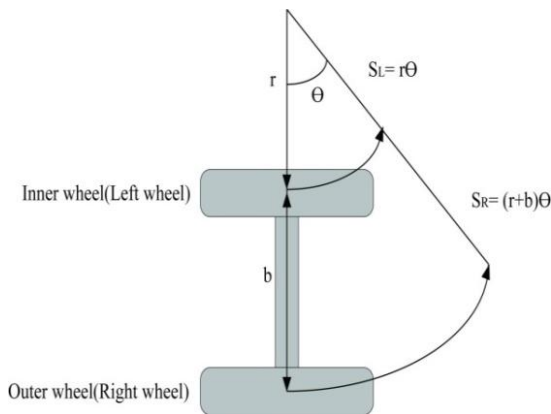

**Figure 4.** Flow control of 'smart parking area'

**90 degree movement of car (left turn/right turn):**

To park the car at any slot, the car has to take 90 degree left/right turn from Mark 2/3. For this we will use concept of differentially steered drive system [9]. The differentially steered drive system to be used is essentially the same as that used in a wheelchair. If both drive wheels turn in synchronisation, then the car will moves in a straight line. If one wheel rotates faster than the other, then the car will follows a curved path inward toward the slower wheel. If the wheels turn at equal speed, but in opposite directions, then the car will rotate. Thus, steering the car is just a matter of varying the speeds of the drive wheels.

If a car has to take 90 degree rotation i.e. a left or a right turn then there are two ways to do so. A simple approach is to stop the car and rotate it by 90 degree about its centre. But such an approach is inefficient and unrealistic and therefore is not possible in practical world. A more realistic approach would be to rotate the car round the corner of the turn following a gradual circular trajectory. For this approach we have to control the speed of the wheels such that the difference between two speeds gives the required 90 degree movement effect. For this we will increase the speed of the outer wheel and at the same time decrease the speed of the inner wheel. If both the wheels turn with constant, but different, speeds, the car will follow a circular trajectory. With that in mind, we see that wheel speeds are selected based on how wide a turn we want our car to take.



**Figure5.** Path of wheels through a turn

Referring to figure 5:

$$SL = r \theta$$

$$SR = (r+b) \theta$$

$$SM = (r+b/2) \theta$$

Where SL, SR represents the distance travelled by the left and the right wheel respectively, r is the turning radius of the inner (left) wheel, b is the distance between left and right wheels, theta is the angle of the turn (in radians), SM is the speed at the centre point of the main axle.

Once we have established the geometry for the differential steering system, it is easy to develop algorithms for constructing trajectory. It is important to note that here we have made an assumption that the wheels rotate with

constant speed. We have neglected the effect of acceleration which would always be there in real world. If we also consider the acceleration effect on wheels of car then determination of the curve path trajectory will become much more complicated. Although when working with very light robots, where the mass (and inertia) of the platform is small, we can often get away with treating changes in speed as nearly instantaneous. Here we are trying to make a model of automated car parking system where a robot car will represent real world car. Since mass of this robot car will be very less so in this case we can neglect acceleration effect of two wheels. The path that the robot car follows will not be truly circular, but it would be somewhat close enough to a circular path. Although in case of real car, of course, mass is important and acceleration must be considered.

**B. SMART CAR**

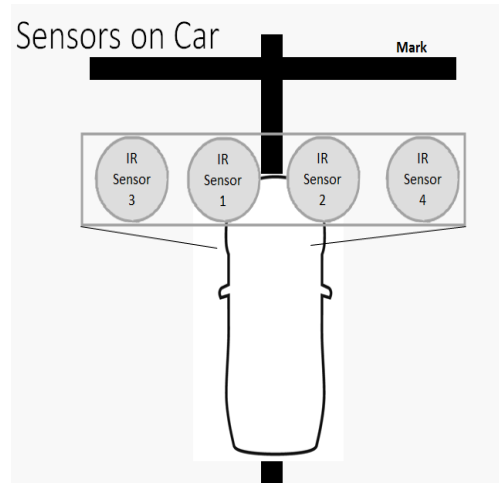

**Figure 6.** Layout of ‘smart parking area’

Figure 6 illustrates layout of smart car. The car will be having four IR sensors at its front bonnet and a microcontroller. IR sensor 1 and 2 will be used to move the car over the black line (using concept of line follower) while sensor 3 and 4 will be used to figure out whenever any “Mark” is encountered.

**Working of IR sensors:**

IR sensor is a kind of active proximity sensors. The module of IR sensor consists of two parts, infrared emitter (source) and infrared sensor. It emits near infrared energy and measures whether any significant amount of IR light is returned or not. Infrared radiation is part of the electromagnetic spectrum, which includes radio waves, microwaves, infrared, visible light, and ultraviolet light, X rays and gamma rays. Wavelength of infrared is in between 700nm to 1mm and frequency of infrared is from 300GHz to 430THz. Black colour being good absorber, absorbs almost all infrared radiations therefore reflecting almost no part of IR energy. On the other hand white colour being best reflector (worst absorber) reflects almost all part of IR that falls into it. As we move from black towards white, at every level of change in shades of grey there is an optimal increase in amount of energy being reflected. This reflected energy is focused onto one or

more photosensitive detectors which then convert this energy into electrical signal.

**Path Detection using IR Sensor:**

We use an IR emitter LED which emits infrared radiations. IR has a property that it is reflected by the white line and absorbed by the black surface. Using this principle we construct a black line follower robot car. A black line is drawn over a white surface. The emitted IR is thus reflected back when sensor comes over a white surface, however no IR is reflected back when sensor comes over a black surface. The reflected IR is detected by an IR receiver photodiode. Photodiode produce a voltage difference across its terminals when it is subjected to light. When the IR is reflected by white surface the voltage drop across the cathode of the receiver LED decreases. This difference in voltage drop across cathode of receiver can be used to detect whether sensor is over white surface or black surface.

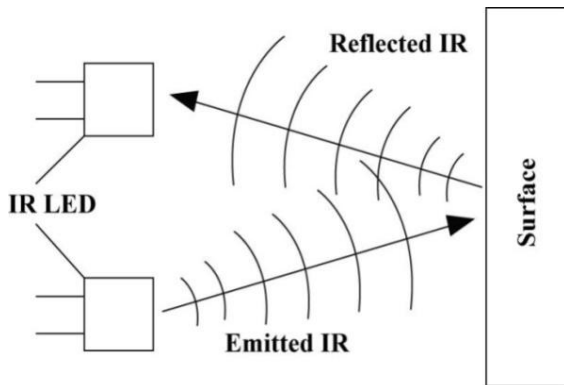

**Figure7.** IR sensor

**Working of sensors of car:**

Since the car will be moving over a Black Path, and the two sensors (sensor 1 and 2) will be projected just outside the path where the surface of parking area is white (light color), so when the car will be moving at that time all four sensors will be ON. If by mistake car moves towards left, then sensor 2 will automatically come over black path, and as black color will absorb all infrared radiations of nothing will be sensed by receiver and sensor 2 will turn OFF. As sensor 2 gets turned OFF, code burned in microcontroller will guide the car to come back to its path i.e. to move slightly towards right and for this controller will switch off right wheel for some time and only left wheel will rotate, which will move the car towards right. When the car will come back over the path, sensor 2 will again turn ON and both wheels will start rotating again. Exactly opposite will happen if the car by mistake moves towards right.

Table I illustrates working of sensor 1 and sensor 2.

**Table I.** Working of Sensor 1 and Sensor 2 of car

Sensor 1	Sensor 2	Movement of car
OFF	OFF	Not Possible
OFF	ON	Car has lost its track and has moved towards right, to bring it back on track switch off left motor & switch on right motor

ON	OFF	Car has lost its track and has moved towards left, to bring it back on track switch off right motor & switch on left motor
ON	ON	Car is moving over black track

**Flow Control:**

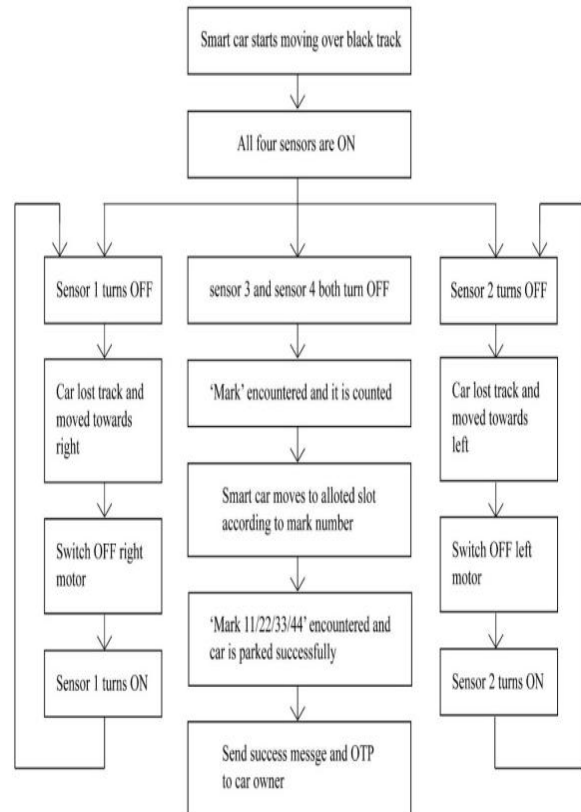

**Figure 8.** Flow control of ‘smart parking area’

Sensor 3 and 4 are to detect Marks present on parking area. When car will be moving both these sensors will be ON because they will be over white surface. When ever any Mark is encountered, since marks are of black color, they will turn off both sensor 3 and 4. So whenever both these sensors get OFF we can notify that a Mark has been encountered. Table II illustrates working of sensor 3 and sensor 4.

**Table II.** Working of Sensor 3 and Sensor 4 of car

Sensor 3	Sensor 4	Movement of car
OFF	OFF	Car has reached to a “Horizontal Mark” (stop at the mark till the next command to move is given)
OFF	ON	Not Possible
ON	OFF	Not Possible
ON	ON	Car is moving over black track

**V. RESULTS**

The above proposed project was divided by us into three stages. First stage was planning and conceptualization in which we made proper planning of this project work



keeping all kinds of practical and real world scenarios in mind. Second stage was software implementation of our project. Since hardware components are very expensive therefore before implementing our project on hardware we did a trial implementation of our project on computer. For writing programs which are to be burned on microcontroller we can use AVR Studio. We can write all our embedded C code for both smart parking area and smart car in this AVR Studio and check it for any syntax or logical error before burning the code on hardware. On the other hand we can design the circuit model of both smart parking area and smart car in Proteus first, and then verify it using code written on AVR Studio. This will help us in finding out any kind of bug, so that when we burn our code on hardware, our hardware does not get damaged. Once software implementation is completed, then we moved to third stage, which is hardware implementation.

## VI. CONCLUSION

This paper proposes an idea of automated car parking system in contrast to manual parking which was dependent on car driver. This idea is implemented using sensors and microcontrollers. This type of automated parking model not only saves time, space and energy but also provides an intelligent way of parking which reduces problems like car collisions and accidents which may arise due to human error and negligence.

Further the design and convention used by us can be made "Standard" so that each and every parking area and smart car can use same standards. Almost all big companies [10] like Ford, Hyundai, Volvo, BMW and Google are working on making driverless car. In future cars will be moving on road without any driver driving it. So our idea of providing an automated car parking area for these driverless cars will be an add-on to these new upcoming technologies because it will provide better parking facility to those driverless cars.

## REFERENCES

- [1] M. M. Rashid, A. Musa, M. Ataur Rahman, N. Farahana, and A. Farahana, "Automatic Parking Management System and Parking Fee Collection Based on Number Plate Recognition," *International Journal of Machine Learning and Computing*, Vol. 2, No. 2, April 2012.
- [2] K. Jiang and L. D. Seneviratne, "A Sensor Guided Autonomous Parking System for Nonholonomic Mobile Robots," *Proceedings of the 1999 IEEE International Conference on Robotics & Automation*, Detroit, Michigan May 1999.
- [3] Zhi-Long Wang, Chih-Hsiung Yang, Tong-Yi Guo, "The Design of An Autonomous Parallel Parking Neuro-Fuzzy Controller for a Car-like Mobile Robot," *SICE Annual Conference 2010 August 18-21, 2010, The Grand Hotel, Taipei, Taiwan*.
- [4] Prof. D. J. Bonde, Rohit S. Shende, Ketan S. Gaikwad, Akshay S. Kedari, Amol U. Bhokre, "Automated Car Parking System Commanded by Android Application," *International Journal of Computer Science and Information Technologies*, Vol. 5 (3), 2014, 3001-3004.
- [5] T. Bhanusri, K. Prabhakara Rao, "Advanced Car Parking System with GSM Supported Slot Messenger," *IOSR Journal of Electronics and Communication Engineering (IOSR-JECE)* e-ISSN: 2278-2834, p-ISSN: 2278-8735. Volume 10, Issue 1, Ver. II (Jan - Feb. 2015), PP 14-18.
- [6] Shihong Qin, Xiangling Yao, "An intelligent parking system based on GSM module", *Appl. Math. Inf. Sci.* 7, No. 1L, 55-59 (2013)

- [7] I.E. Paromtchik and C. Laugier, "Autonomous Parallel Parking of a Nonholonomic Vehicle", *IEEE Intelligent Vehicles Symposium*, NJ
- [8] F. Gbmez-Bravo, F. Cuesta, A. Ollera, "Autonomous Parking and Navigation by Using Soft-Computing Techniques".
- [9] A Tutorial and Elementary Trajectory Model for the Differential Steering System of Robot Wheel Actuators by G.W. Lucas.
- [10] Daniel Howley, Technology Reporter (February 13, 2016), "Self-Driving Cars Are Coming Soon to a Highway Near You," *Yahoo News*. Retrieved from <https://in.news.yahoo.com/self-driving-cars-are-coming-soon-to-a-highway-221223190.html>