

*Note: All questions are compulsory. Marks are indicated against each question in square brackets. IS-800:2007 and IS808 Steel Table is allowed.*

- Q1. Find the maximum for  $P$ , the bracket of thickness 10 mm can transmit. Bolts used are M20 ordinary bolt of grade 8.8. [5 Marks]

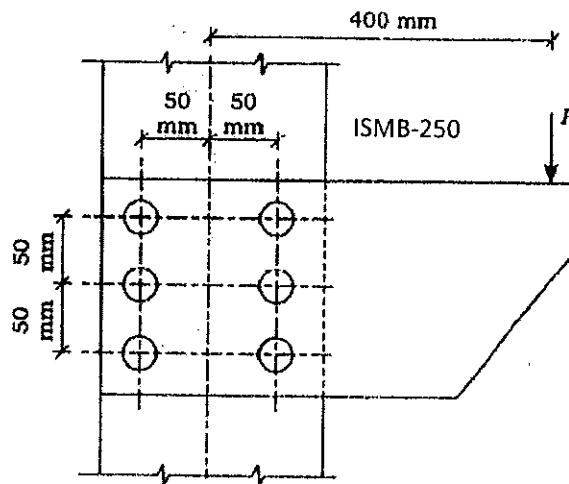

- Q2. A tie member consists of two **ISMC 250**. The channels are connected on either side of a 12 mm thick gusset plate. Design the welded joint to develop the full strength of the tie. However the overlap is to be limited to 400 mm. [5 Marks]

- Q3. A simply supported 2-D roof truss, Service loads at different nodes has been shown in figure. Members at each joint are connected on gusset plates of thickness 10 mm and M22 bolts of grade 5.6, such that shear plane in bolts passes through shank zone only. Joints can be treated as rigid. Design the member **BD** with an equal angle section and take a case of tension only. [5 Marks]

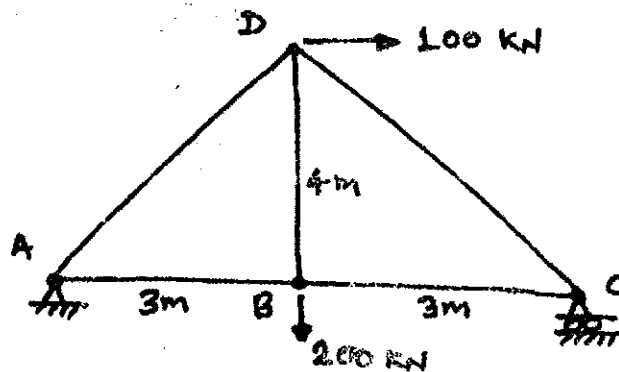

**Q4.** A single ISA 100x75x10 is used in a tension member with the longer leg connected to a 10 mm thick gusset plate. The connection is made with the help of a lug angle. Design the connection and sketch the bolt details. Use M20 bolts of grade 4.6 having bolt value of 45.27 kN. Section available for lug angle are: (a) ISA 60x60x8 – 896 mm<sup>2</sup>, (b) ISA 60x60x10 – 1100 mm<sup>2</sup>, (c) ISA 70x70x8 – 1200 mm<sup>2</sup>. [5 Marks]

**Q5.** Determine the load carrying capacity of the column section shown in Figure below, if it's actual length is 4.5 m. It's one end may be assumed fixed and the other end hinged. The grade of steel is Fe 415,  $E = 200000$  Mpa. [5 Marks]

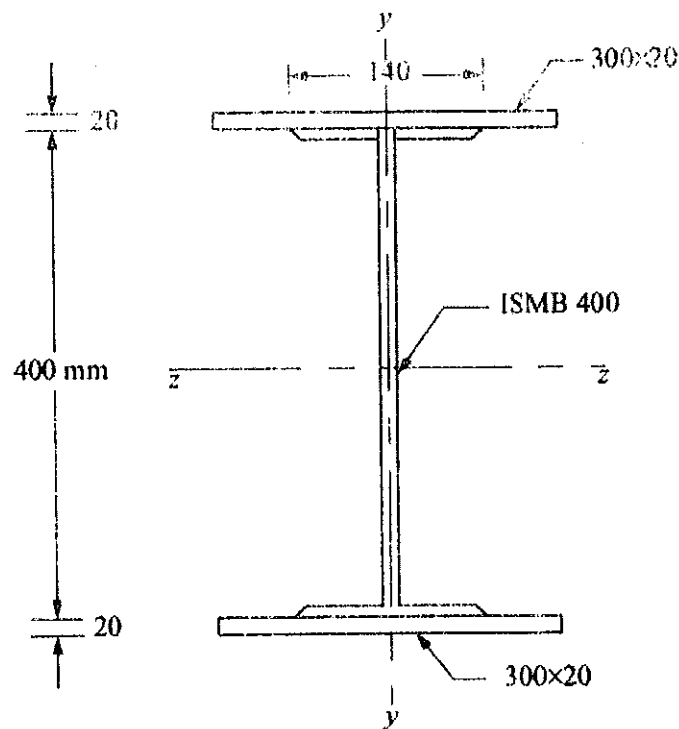

Sectional Properties:

For ISMB 400: Area = 7846 mm<sup>2</sup>.

$h = 400$  mm,  $b_f = 140$  mm,  $t_f = 16$  mm,  $I_{zz} = 20458.4 \times 10^4$  mm<sup>4</sup>,  $I_{yy} = 622.1 \times 10^4$  mm<sup>4</sup>,

**For Built up Section (ISMB400 + Plates attached on flange of ISMB 400)**

$$I_{zz} = 73378.4 \times 10^4 \text{ mm}^4,$$

$$I_{yy} = 9622.1 \times 10^4 \text{ mm}^4$$

-----End-----